



ΠΟΛΥΤΕΧΝΕΙΟ
ΚΡΗΤΗΣ



Εργαστήριο Μελέτης και Σχεδίασης με Χρήση Η/Υ

Εγχειρίδιο για την χρήση του SIEMENS NX 11.0

6^ο ΜΕΡΟΣ

ΑΣΚΗΣΕΙΣ ΠΑΝΩ ΣΤΟ SIEMENS NX 11.0



The image displays the Siemens NX 11.0 software interface. On the left, a grid of images shows various products: a blue motorcycle, a white cruise ship, a white airplane, a red sports car, a blue and white helicopter, and a blue and white golf ball. The Siemens logo is prominently displayed in the top left corner of the grid. On the right side of the interface, the text "Siemens PLM Software" and "NX" are visible. At the bottom right, the version information "Version 11.0" and "© 2016 Siemens Product Lifecycle Management Software Inc." is shown.

SIEMENS

Siemens PLM Software
NX

Version 11.0
© 2016 Siemens Product Lifecycle
Management Software Inc.

ΕΙΣΑΓΩΓΗ

Σε αυτό το 6^ο και τελευταίο μέρος του εγχειριδίου περιέχονται διάφορες εικόνες μοντέλων συνοδευόμενα από τα Drawings και τα Exploded Views τους τα οποία θα χρησιμοποιήσετε για τον σχεδιασμό τους στο Siemens NX 11.0. Οι ασκήσεις αυτές, προορίζονται για καλύτερη εξοικείωση με το πρόγραμμα και έχουν ως στόχο το να αποκτήσετε δεξιότητες και αυτοματισμούς καθώς το χρησιμοποιείτε. Γι' αυτό τα μοντέλα δεν συνοδεύονται από οδηγίες και άλλες εικόνες και συνεπώς χρειάζεται να έχετε καλή γνώση του προγράμματος και των εντολών του, ιδιαιτέρως αυτών που χρησιμοποιήθηκαν στα προηγούμενα Tutorial. Μπορείτε επίσης να δώσετε κίνηση σε κάποια μέρη των μοντέλων.

ΑΣΚΗΣΗ 1

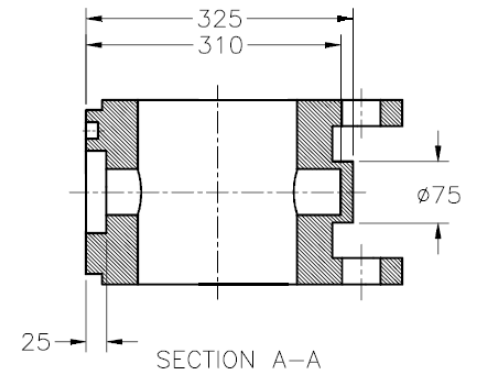
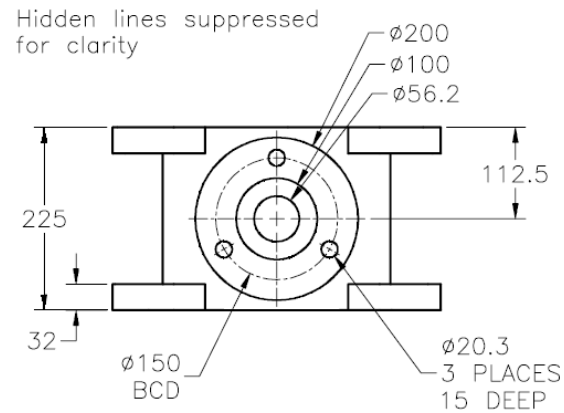
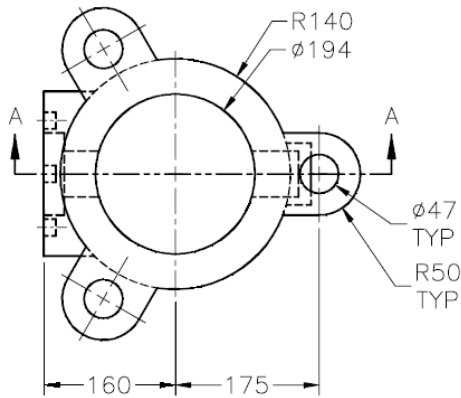
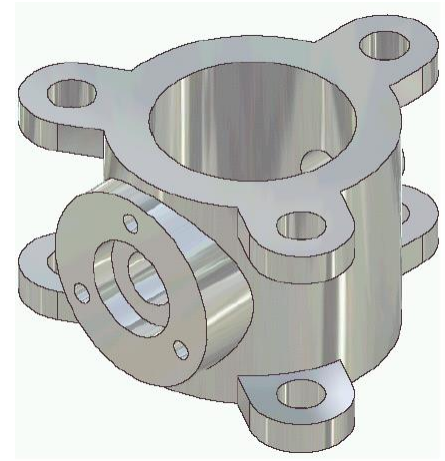
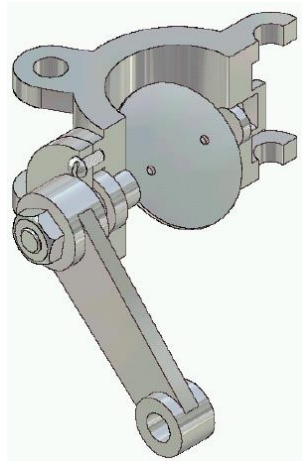
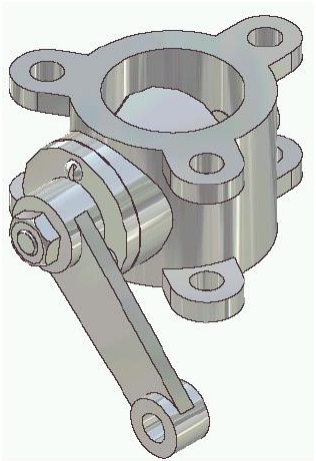

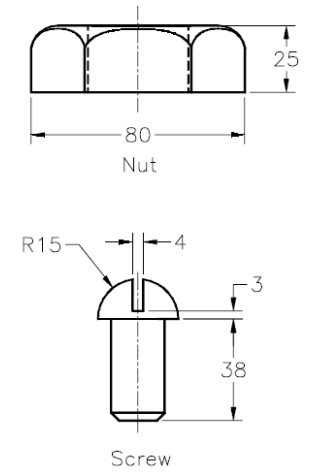
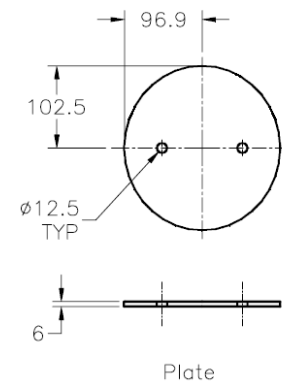
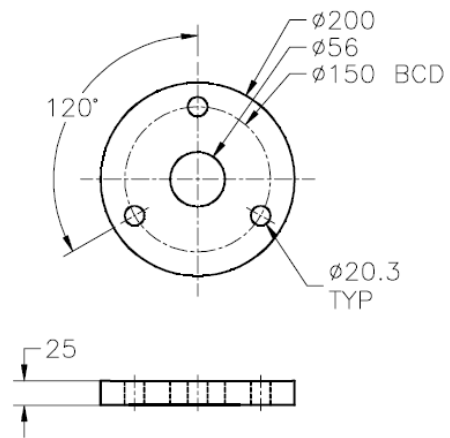
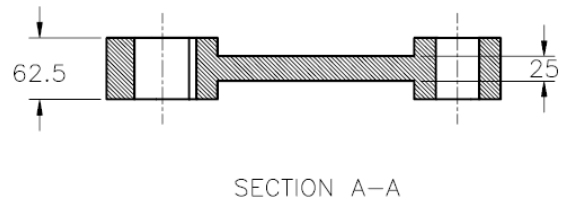
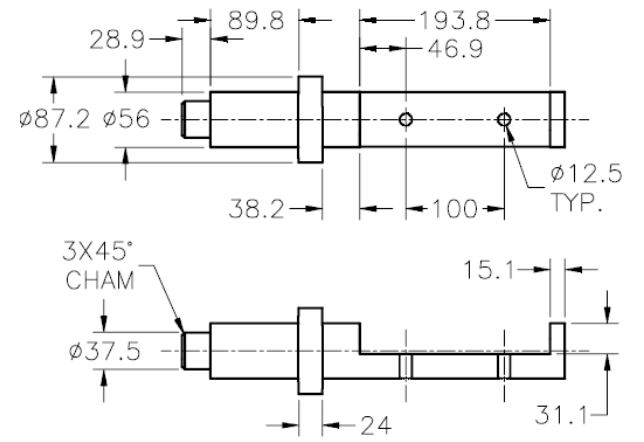
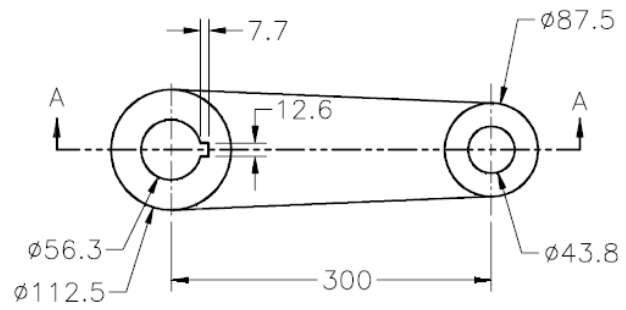

ΑΣΚΗΣΗ 2

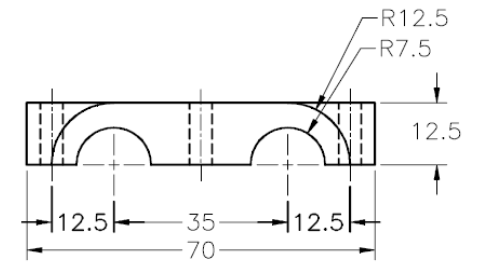
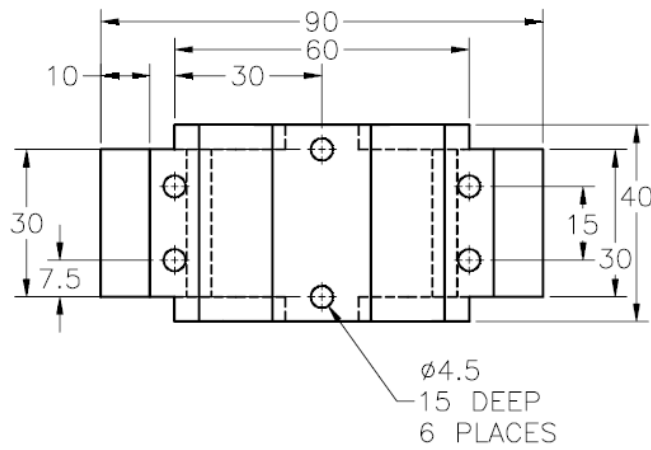
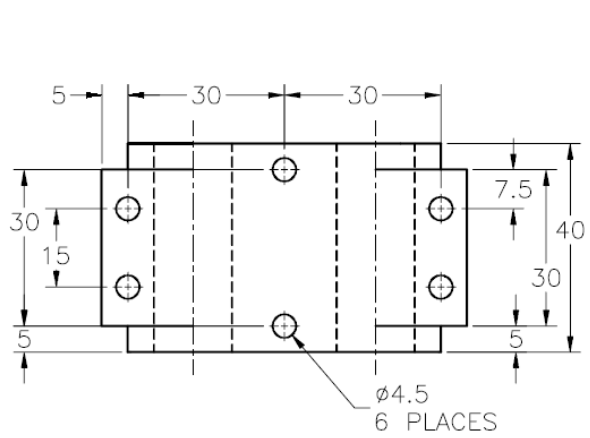
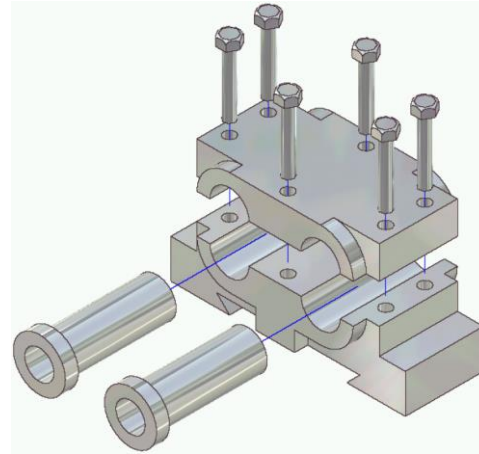
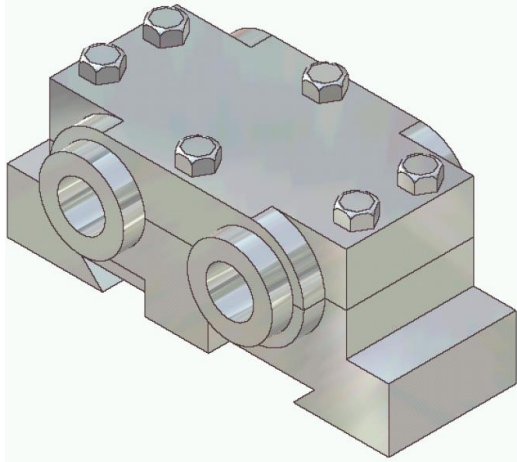

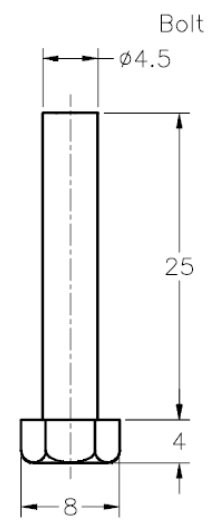
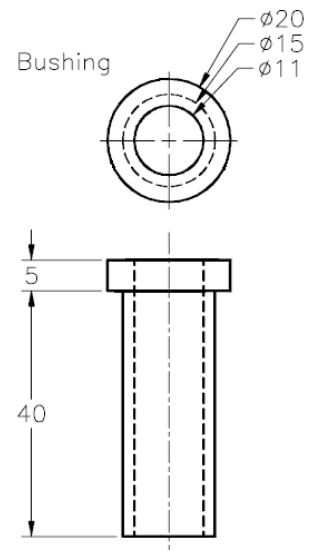
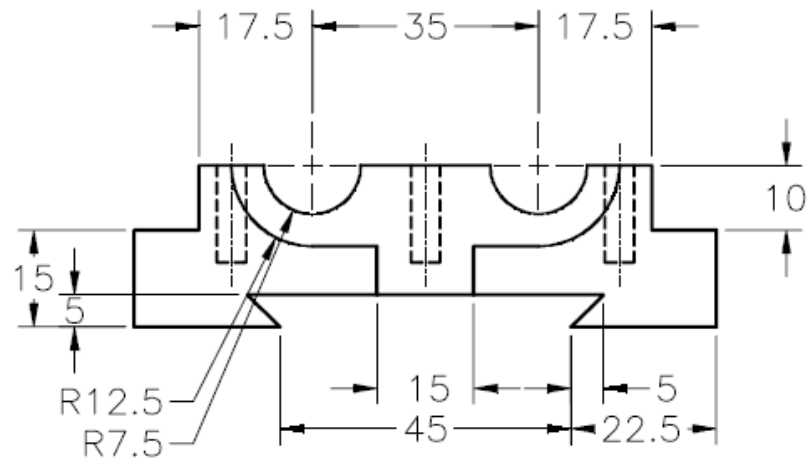

ΑΣΚΗΣΗ 3

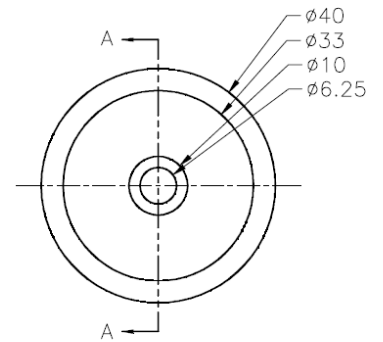
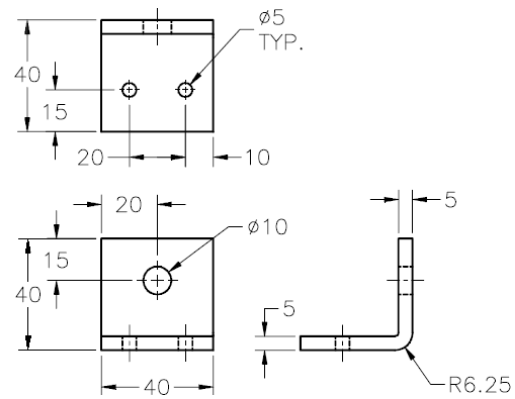
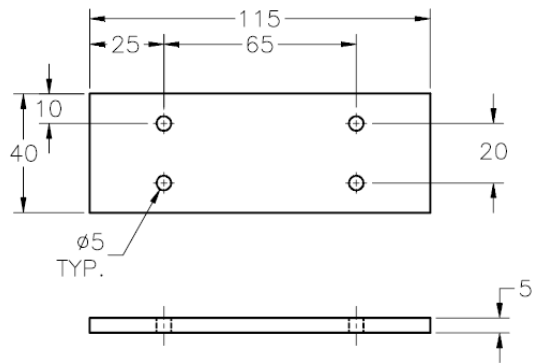
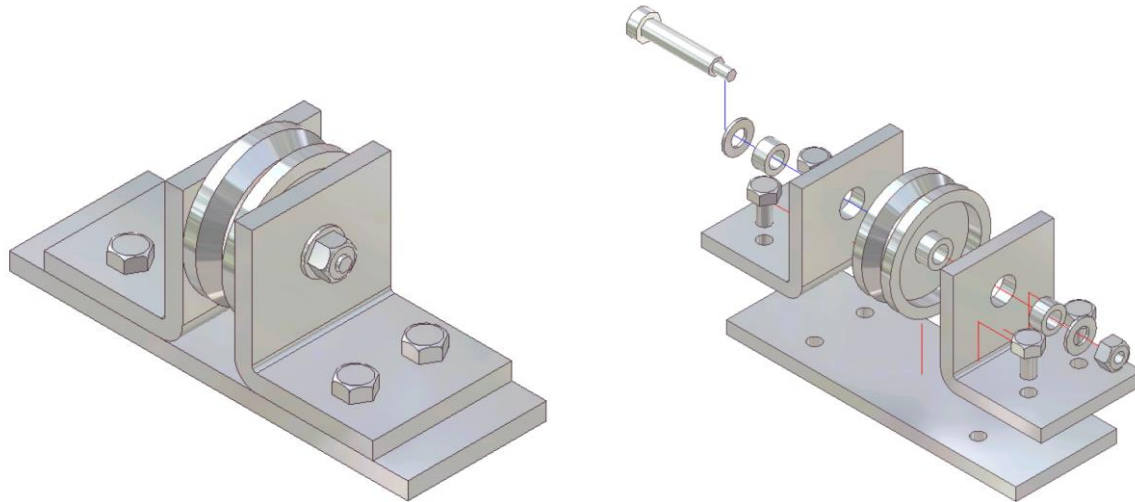

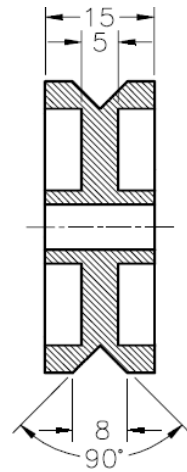

SECTION AA

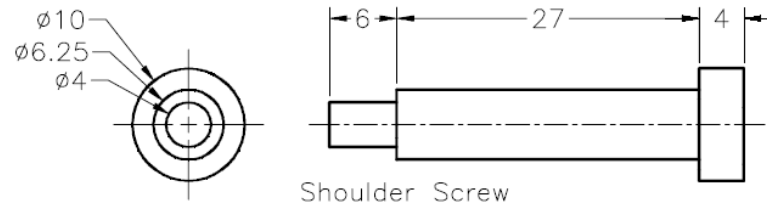

Shoulder Screw

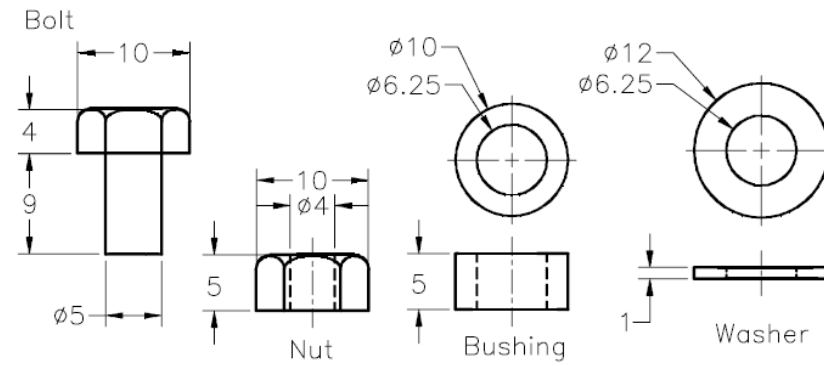

ΑΣΚΗΣΗ 4

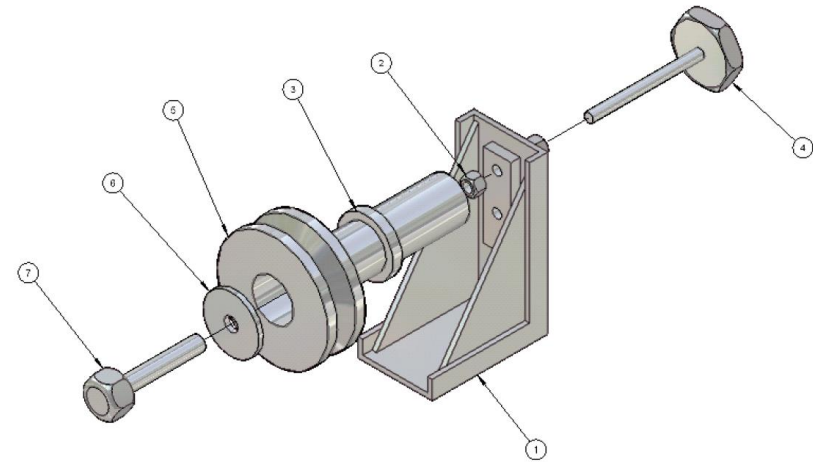
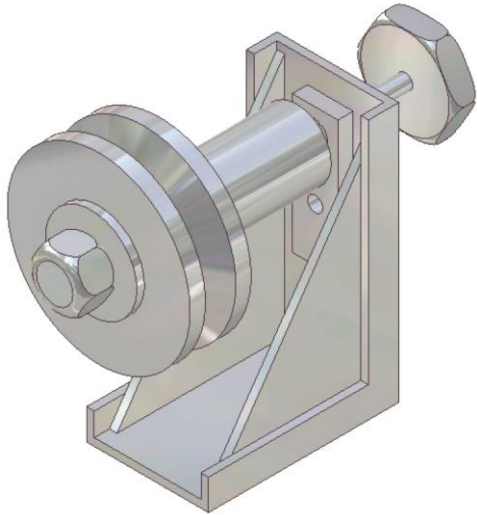

PARTS LIST			
ITEM	QTY	NAME	MATERIAL
1	1	Bracket	Steel
2	2	Nut	Steel
3	1	Bushing	Steel
4	1	Turn Screw	Steel
5	1	Pulley	Steel
6	1	Washer	Steel
7	1	Cap Screw	Steel

